



Multi-Application DSP Amplifier



**Flexible
Powerful
Economical**

Product Data Sheet

Product Overview

Spin NR is a two-channel, multi-application digital amplifier with trimmer control capability. This amplifier provides powerful features at an economical cost, making it ideal for a wide range of cost-sensitive hearing-aid applications. Spin NR also features 12-band gain adjustment, allowing for excellent target matching capability. Powerful Dynamic Contrast Detection™ 2-channel compression with three-mode adaptive time constraints optimizes AGC performance in critical environments. This amplifier is ideal for both programmable and trimmer-controlled hearing aids, and is excellent as an analog replacement and as a convenient way to consolidate your hearing aid product line.

Spin NR's Layered Noise Reduction™ includes a syllabic layer, which reduces noise that is embedded in speech, an environment layer which slowly reduces environmental noise in the absence of speech, and a quick recovery layer that gives noise reduction with fast recovery for speech onset. All layers are responsive to a wide range of noise intensities, and the addition of programmable selection allows the wearer to maximize both comfort and speech quality.

IntriCon's Advanced Adaptive Feedback Cancellation allows for 17-22 dB of added stable gain depending on the application, creates 15 dB more fitting range than our previous generation AFC, and offers superior handling of tonal sounds. Unlike conventional adaptive notch filters, Advanced AFC will not reduce gain.

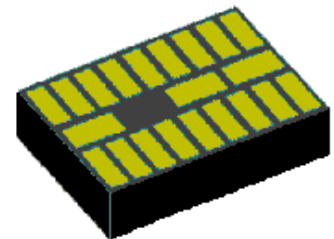

PCB Hybrid for Reflow and Hand-wire Applications - RoHS-compliant



Feature List

Layered Noise Reduction

- Syllabic layer reduces noise that is embedded in speech
- Environment layer slowly reduces noise when no speech is present
- Quick-Recovery layer gives noise reduction with fast recovery for speech onset
- All layers respond to noise of all intensities - replaces low-level expansion
- Programmable selection to maximize comfort or maximize speech quality

Advanced Adaptive Feedback Cancellation*

- **17-22 dB of Added Stable Gain**, depending on application
- 15 dB more fitting range than our previous generation of AFC
- Doesn't reduce gain like conventional adaptive notch filters
- Improved handling of tonal sounds

Suitable for a Wide Range of Applications

- Cost-sensitive **Open-Ear BTEs** - programmable or trimmer-controlled
- Trimmer-controlled hearing aids
- Analog replacement
- Product line consolidation

Powerful Dynamic Contrast Detection™ 2-channel Compression

- Three-mode adaptive time constants to optimize AGC performance in critical environments

12-Band Gain Adjustment

- Excellent target matching capability

Trimmer Control Capability

- Factory-programmable setup for controlling TK, Low-cut, High-cut, and MPO
- Use 100kohm linear-taper trimmers for any function
- Use 1-3 trimmer as needed

Low-level Expansion

Automatic Telecoil & MTO Switch Compatible

Programmable VC Range

- Customize VC performance at design, manufacturing or fitting time.

Program Switch Tones

- Adjustable frequency and loudness. or disable

Mic+Telecoil Input Summing Mode

Low Battery Warning

- Adjustable frequency and loudness. or disable

Feature Descriptions

Adaptive Feedback Cancellation (AFC)

The feedback canceller in this amplifier uses the normalized Least-Mean-Squared technique (NLMS) with special patent-pending modifications to improve the resistance to entrainment. This technique is also called phase cancellation. Entrainment is the tendency of a feedback canceller to become confused by tonal sounds. This can cause false whistling and squeaks. The anti-entrainment functions acts to prevent problems caused by single tones, multiple tones, and loud complex sounds. Laboratory tests of the AFC function show that it adds as much as 17 dB of gain compared to when AFC is turned off - known as *Added Stable Gain*. The AFC is effective for feedback problems occurring in the frequency range of 1.3 kHz to 6.7 kHz. The AFC can be enabled or disabled separately in each user memory by programming. Additional information on this feature can be found in the IntriCon technology white paper titled "Advanced Adaptive Feedback Cancellation," (available on the IntriCon web site, or from your IntriCon sales representative).

Layered Noise Reduction

Our unique version of noise reduction acts to remove noise in between speech syllables as well as to lower general background noise from the environment. All layers respond to noise of all intensities so it replaces the function of low-level expansion. The LNR function can be set to the following settings: Off, Low, Medium, and High. Additional information on this feature can be found in the IntriCon technology white paper entitled "Understanding Layered Noise Reduction," (available on the IntriCon web site, or from your IntriCon sales representative).

Dynamic Contrast Detection Compression

The Spin amplifier uses unique IntriCon technology called Dynamic Contrast Detection in the 2-channel WDRC compression system. The technology is described in detail in the technology white paper titled *Two-Channel WDRC Compression with Dynamic Contrast Detection*. (available on the IntriCon web site, or from your IntriCon sales representative). Compression thresholds settings for both channels together are 40, 45, 50, 55, 60, 65, 70 dB SPL input-referred. Compression ratios settings of each channel are 1:1, 1.14:1, 1.33:1, 1.6:1, 2.0:1, 2.65:1, 4.0:1. Time constants settings are described in the technology white paper mentioned above. Compression thresholds can also be trimmer controlled.

Expansion

The amplifier offers low-level expansion to reduce the effects of microphone noise and low-level environmental noise. The system can be turned on or off by programming. The expansion threshold is 50 dB SPL relative to the input pads, and the expansion ratio is 2:1. The expansion time constants are 25 msec. attack time and about 300 msec. release time.

Band Gain Equalizers

Twelve band gain adjusters - equalizers - are available to precisely match fitting targets. Band 1 covers the frequency 250 Hz and below. Bands 2-8 are 500 Hz wide. Bands 9-12 are 1000 Hz wide. Center frequencies of bands are: ~100, 500, 1000, 1500, 2000, 2500, 3000, 3500, 4250, 5250, 6250, 7250 Hz. Each band has adjustable gain in 2 dB increments from 0dB to -30 dB.

Input Modes

There are four single input modes: MIC1, MIC2, TC+, and DAI. When one of these modes is activated, the input pad by that name is active, and all other inputs are turned off. Inputs MIC1 and MIC2 have internal AC coupling capacitors. Inputs TC+ and DAI are DC coupled and usually require an external AC coupling capacitor. There are two summing modes available. Mode MT1 allows the inputs MIC1 and TC+ to be active simultaneously and their signals are summed after preamplification. Mode MT2 allows the inputs MIC2 and DAI to be active simultaneously and their signals are summed after preamplification.

Preamplifiers

There are two adjustable preamplifiers to handle the four input pads. Preamplifier 1 handles inputs MIC1 and DAI. Preamp 2 handles inputs MIC2 and TC+. Each preamp is programmable to the settings 0, 12, 15, 18, 21, 24, 27, and 30dB gain.

High Cut Filter

This filter emulates a 2nd-order butterworth-tuned low-pass filter. This gives a 12dB/octave rolloff above the corner frequency. Programmable corner frequencies values are 8000, 4000, 3150, 2500, 2000, 1600, 1250 Hz.. The corner frequency can also be trimmer controlled.

Output Limiting

The maximum power output (MPO) of the amplifier can be limited using the compression limiter. This method of output control does not create harmonic distortion like peak clipping. The MPO can be programmed to settings of 0, -4, -8, -12, -16, -20, -24dB (relative to no limiting). The output level will not be affected by the volume control setting, since the limiter is placed right before the output stage and after the VC block.

Trimmer Control

The amplifier offers trimmer control capability of several of the programmable parameters. Up to 3 trimmers can be configured. To create a trimmer control, a 100kohm linear-taper trimmer (such as IntriCon models 17, 37, and 75) is wired with the center terminal to the T1, T2, or T3 pad, and the ends of the trimmer are wired to M+ and GND respectively. The one of the trimmer-controllable parameters is assigned to that trimmer by setting the 'mapping' parameter by programming. The parameters that can be trimmer controlled are Low-cut, High-cut, TK, and MPO. For example, to assign trimmer 1 to the Low-cut parameter, set the LC_MAP parameter to 1. Each trimmer can adjust each parameter to one of 7 settings linearly spaced over the rotation of the trimmer.

Volume Control Function

A user volume control can be connected to this amplifier, and the function can be configured to match the application. To create a volume control, a 100kohm linear-taper VC (such as IntriCon models 11, 12, 14, 25, 26, and 35) is wired with the center terminal to the VC pad, and the ends of the VC are wired to M+ and GND respectively. By programming, the VC can be enabled or disabled. The range of the VC is programmable to the settings 50dB, 40dB, 30dB, 20dB, 10dB.

Automatic Telecoil and MTO Switching

A dedicated switching pad is available for applications of automatic telecoil switching or M-T-O switching. This mode is used by attaching a magnetic switch or mechanical switch from the TSW pad to GND. By programming, the 'auto-tcoil' mode is activated and the auto-tcoil program is designated by setting the parameter coilPGM. In the designated auto-tcoil program, the parameters are set to activate the telecoil and adjust other parameters to the desired telecoil performance. When the TSW pad is pulled to GND, the amplifier switches to the program set by coilPGM (typically program 5) and stays there until the TSW pad is open. The amplifier reverts to the user memory that was active just before TSW was grounded.

Low Cut Filter

This filter is placed in the front end of the amplifier before the bands are split. It is implemented with a 2nd-order butterworth-tuned infinite-impulse-response (IIR) high-pass filter. This gives a 12dB/octave smooth linear rolloff below the corner frequency. Programmable corner frequencies values are 200, 500, 750, 1000, 1500, 2000, 3000 Hz.. The corner frequency can also be trimmer controlled.

Feature Descriptions

Output Mode

There are two output modes available on this amplifier. The switching output mode uses the pads OA and OB for so-called 'Class D' output, to be used with zero-bias receivers. The auxiliary output mode sends a non-amplified analog signal out of the AUXOUT pad when a separate output stage is used.

Tone Adjustments

The tones used for program switching and low battery warning are created in a front-end tone generator. Thus the tones are input referred, and will be affected by the settings of band gain, overall gain, filters, and compression, etc. Available frequency settings are 500, 1000, 1500, and 2000 Hz. Available loudness settings are 60, 66, 72, and 78 dB SPL referred to the input pads.

SDA Programming Port

Communication to and from the amplifier is by means of the so-called SDA port. This port implements a proprietary bidirectional communication protocol with data and clock on the same line. Low-level PC-to-amplifier communication is handled by a dynamic-linked library **spin.dll** provided by IntriCon. This driver supports the HiPro interface unit, as well as MicroCard, MicroConnect, and others. Contact IntriCon for the latest support information, or check our website at www.intricon.com.

Manufacturer's ID

An 8-bit memory location is reserved to store a code called `Manf_ID`. This code is assigned by IntriCon to each manufacturer that requests a unique code. This can be used to identify hearing aids of a given manufacturer from others. IntriCon's engineering software called "Slider" will not read and program amplifiers with the `Manf_ID` set to values other than zero, unless the code has been unlocked using the proper key provided by IntriCon. This prevents undesired changing of hearing aid parameters.

Overall Gain

The parameter for overall gain of the amplifier is also called Matrix Gain. It is adjustable in 1dB steps from 0 to -47dB. Use this parameter to set to set the overall gain of an application, and then use the band gain adjusters to handle frequency shaping. The user VC adjustment will reduce the gain downward starting at the setting of matrix gain. It is important to remember that some values of matrix gain will be too high for a particular application, and the fitting system should insure that these high values are not available at fitting time.

User Program Memory

As many as five user memories are available to an application. Up to four memories are available by selecting the value of the parameter "number_of_programs" by programming to 1-4. A fifth user memory can be added by activating the auto-coil function, and defining the auto-coil memory to be 5. Each of the user memories is a unique set of audio parameters. All of these parameters change when the user changes memory. The program change is accomplished by grounding the SW pad of the amplifier. There are two modes for this switch function. The static mode allows changes from program 1 to program 2 only. When the switch is open, the user program 1 is active. When the switch is grounded, user program 2 is active. In the momentary mode, every time the SW pad is grounded, the user program is incremented, until the top program is active. The next SW grounding event causes the user program to return to program 1. Program switch tones will sound if this feature is enabled (see section 'Program Switch Tones').

Scratch-Pad Memory

Ten memory locations are provided to store any hearing aid and fitting system information that is desired. Each location is 16 bits long. Typical stored items are model code, serial number, calibration constants, version numbers, etc.

Program Switch Tones

When this feature is enabled by programming, the amplifier will emit beeps every time the SW pad is connected to ground. The number of beeps duplicates the program number being switched into, i.e. when moving into program 2, two beeps will be heard. When moving into program 4, four beeps will be heard. The frequency and loudness of the beep tones are programmed as set forth in the section 'Tone Adjustments.'

Low Battery Warning

When the battery voltage nears the end of life, the amplifier will detect this condition and provide a low battery warning signal. The first warnings begin when the average battery voltage falls below 1.05V. At this time, the amplifier emits three sets of double beeps every 10 minutes. When the average battery voltage falls lower than 0.95V, the amplifier issues six sets of double beeps, and then shuts down the audio output of the hearing aid. The frequency and loudness of the beep tones are programmed as set forth in the section 'Tone Adjustments.' Low battery warning can be disabled by programming.

Wiring Schematic showing full features

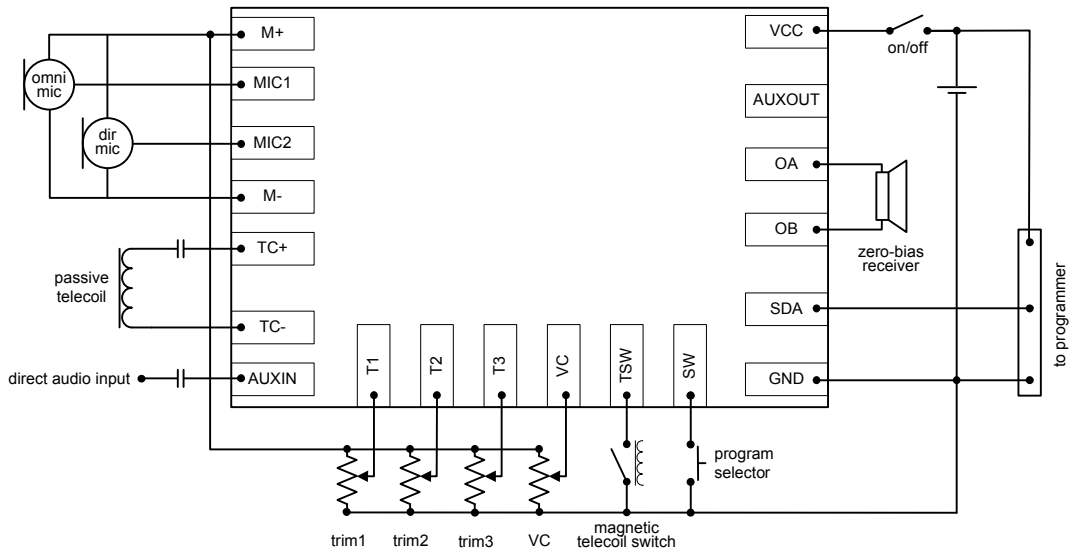

Wiring Schematic for simple programmable application

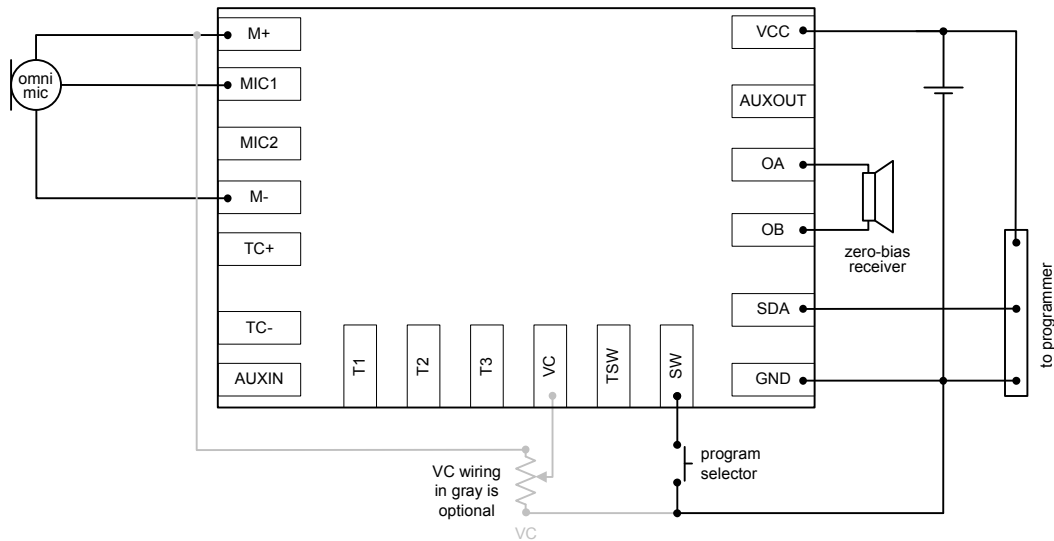

Wiring Schematic with Active Tcoil, VC, DAI, and MTO switch

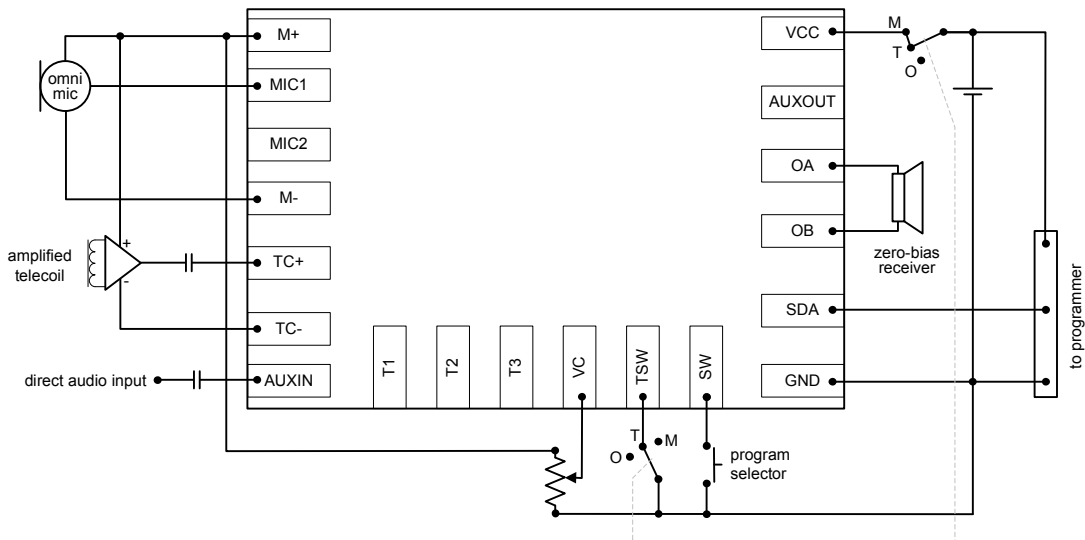

Wiring Schematic showing VC with Switch

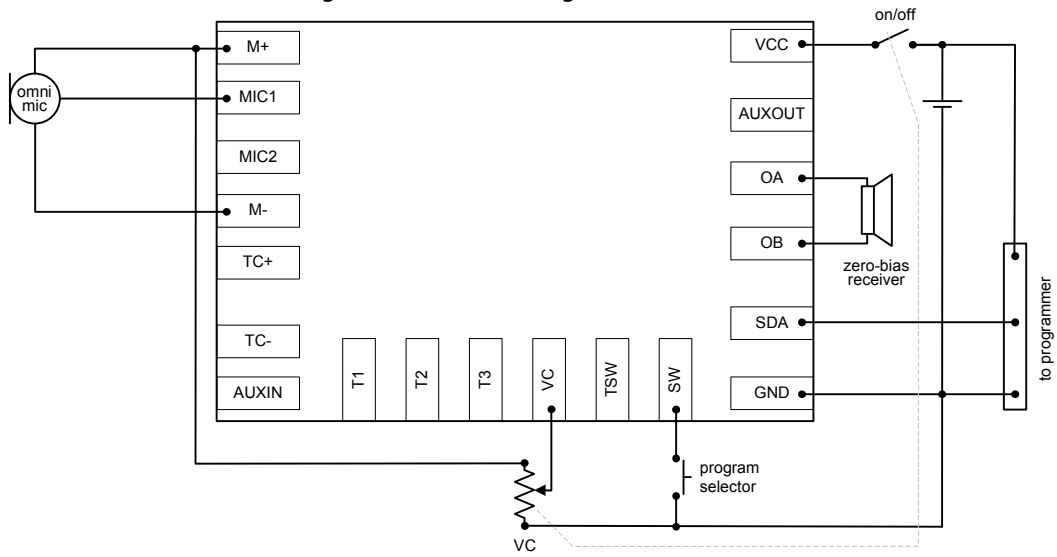

Programmer Wiring

Pin numbering of the DIN connector on the front of the HiPro, as seen facing the HiPro box

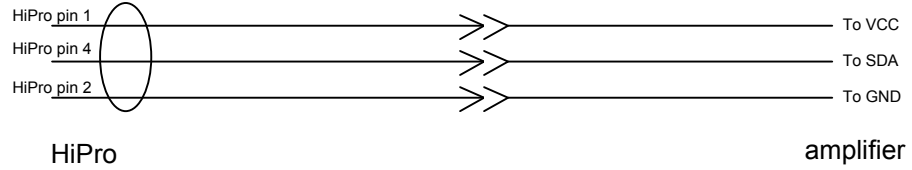
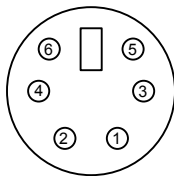

Parametric Data

parameter	minimum	typical	maximum	units	condition
minimum operating supply voltage	1.05	--	--	V	
maximum operating supply voltage	--	--	1.5	V	
supply current, AFC on	--	870	--	uA	tentative, see note 1
clock frequency	2.534	2.560	2.586	MHz	
sampling frequency	--	16	--	kHz	
bandwidth	--	8	--	kHz	
input noise	--	4	--	uV	bandwidth 200-8Khz
dynamic range	--	84	--	dB	max input signal with THD < 2%
output impedance	--	10	--	ohms	
maximum output drive current	--	--	25	mA	
input impedance	385	550	715	ohms	
regulator voltage	0.89	0.95	1.05	V	120uA load
maximum regulator current	100	--	--		
PSRR	35	50	--	dB	
Power on Reset Threshold Voltage	0.55	0.7	0.85	V	

note 1: AFC turned on. 2kHz pure tone input at 200 uVrms amplitude. No connections to OA and OB pads.

Soldering Information

IntriCon Hybrid part number	Customer Attach process	Process Parameters	Max Hybrid Temp	Recommended materials to attach hybrid
91969-0009	Hand solder wire	Set iron tip temp to 650-715 F. Max dwell time of 2 second. Allow 10 seconds between solder operations	250 C	Use SAC 305 solder wire
91969-0009	Flip Chip	Reflow in convection oven – See profile below for recommended reflow temperature.	250 C	Print SAC 305 paste onto pads. Flip hybrid onto wet paste and reflow. Alternate method is to apply flux to the pads then flip hybrid onto fluxed pads and reflow. Recommended flux is Indalloy tac flux 009 (this is a water soluble flux.)

