

Clari-D[®] Linear

Product Data Sheet

Features	Benefits
featuring: Clari-D <i>The Next Generation of Clear Sound Technology</i>	Clearer-sounding, efficient output power for most applications. Eliminates cost of integrated receiver.
Three stage linear amplifier	Provide full flexibility for trimmer options
Low Noise Preamp - 1.85uV rms, input referred, typical	Very quiet
Built-in Regulator - no external capacitor required	Good end of life performance, good power supply rejection
Ultra-Small Ceramic Hybrid Size: 0.085 x 0.160" [2.16 x 4.06 mm]	Perfect for tiny CIC aids! Simple solution for all custom applications and low-cost BTE's

Block Diagram of Clari-D Linear Package

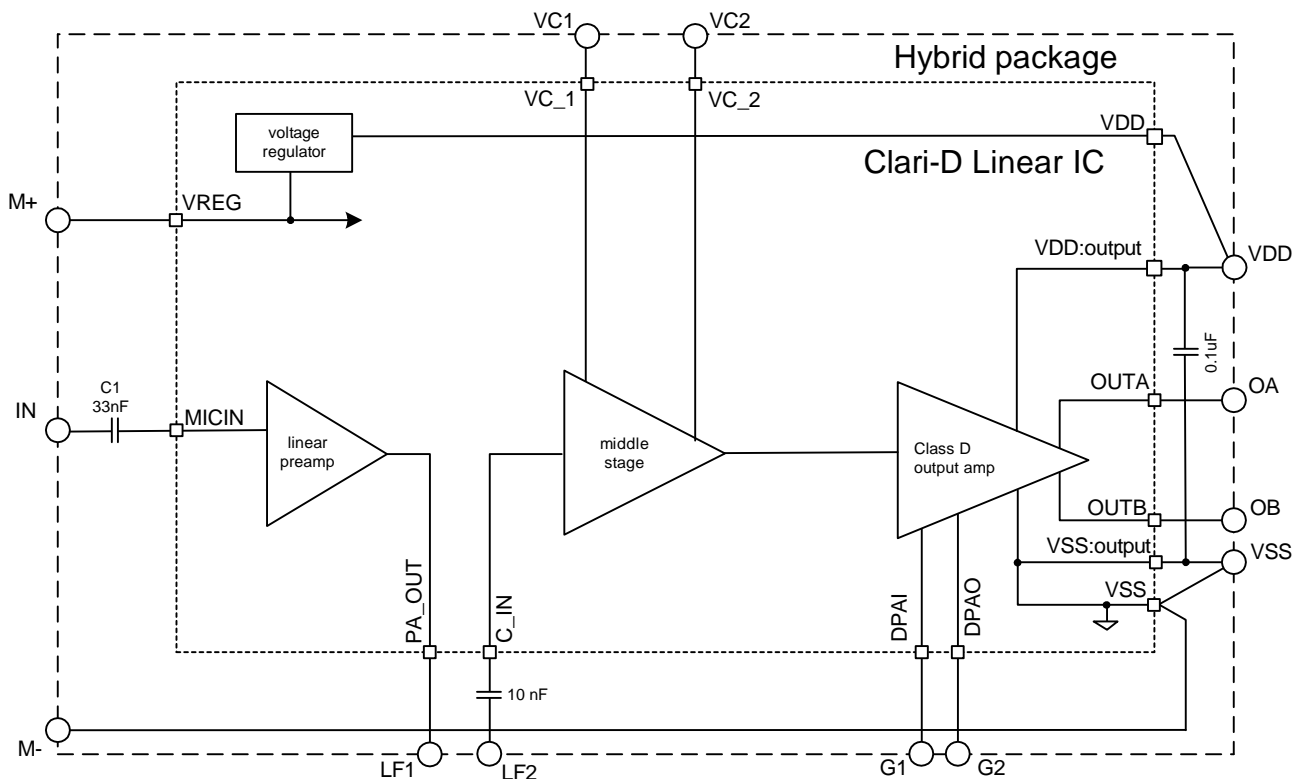

Typical Full Feature Application

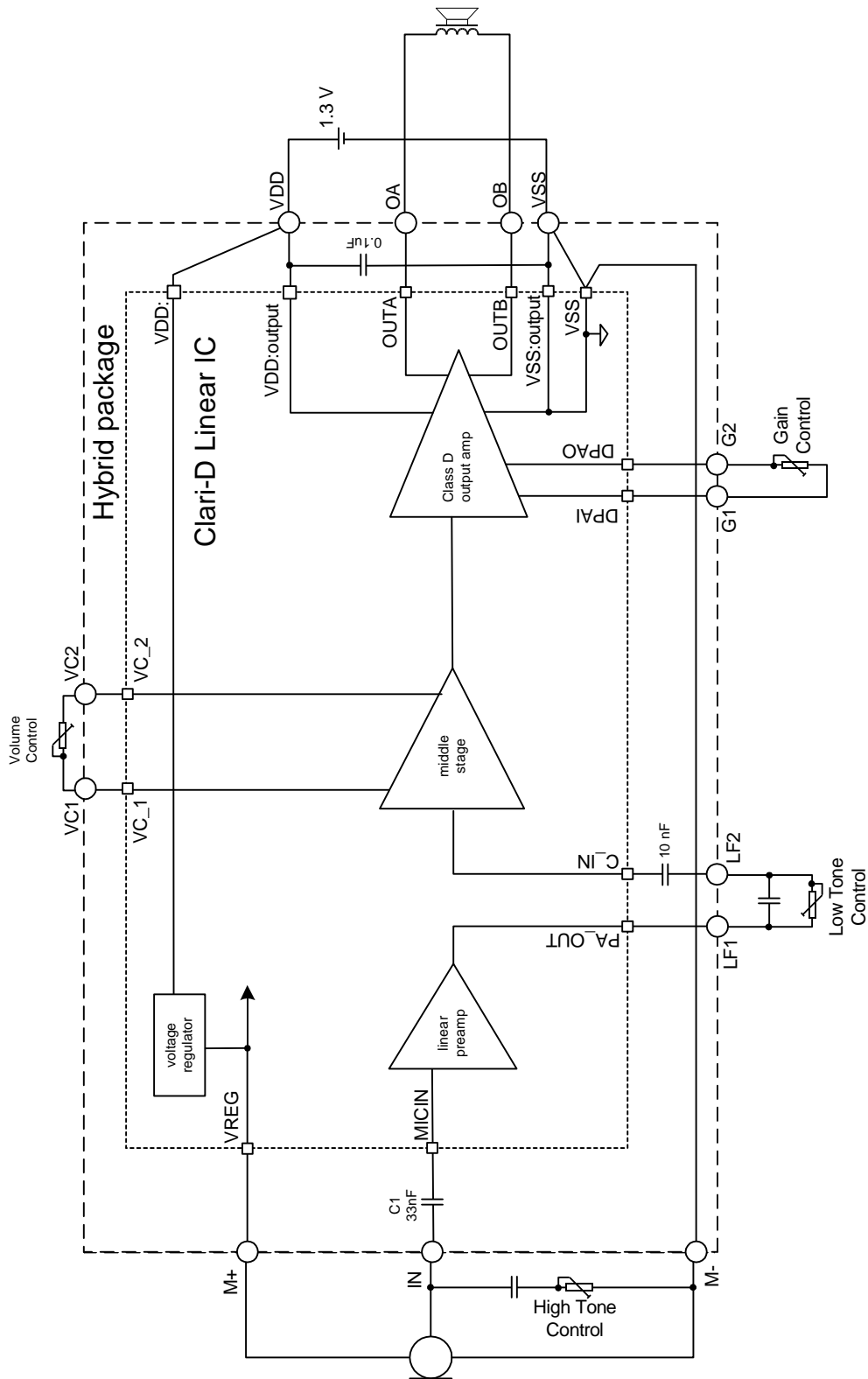

Application: Custom Linear 115/47 10 slope

Recommended uses: ITE, ITC with 13, 312 & 10A battery

Receiver: 26A03 or EH7154

Mic: EM3346

Acoustic data (ANSI S3.22-1996)

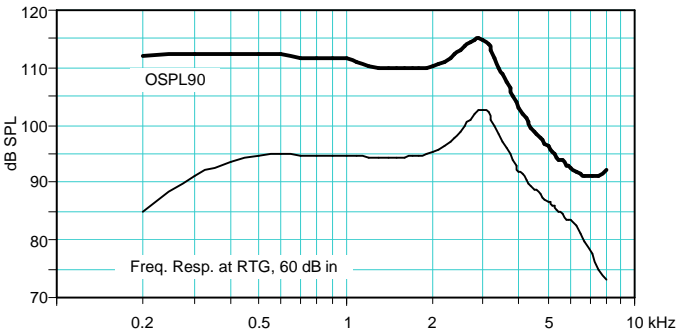

Peak OSPL90 - 115 dB SPL
 HFA OSPL90 - 111.3 dB SPL
 Peak FOG - 47 dB
 HFA FOG - 40.4 dB
 RTG - 34.3 dB
 Freq range - 200-8000 Hz

THD 500Hz - 1.6 %
 800 Hz - 1.6%
 1600 Hz - 1.6%
 EIN - 27.6 dB
 Battery Drain - 0.40 mA

Gain adjust - fixed

select R_{gain}

peak gain	R_{gain}
47	open
42	270k
37	100k
32	43k

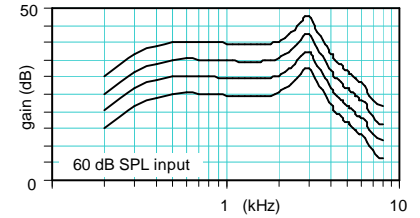

Gain Trimmer

use 1 Mohm, C22 trimmer and 18kohm resistor

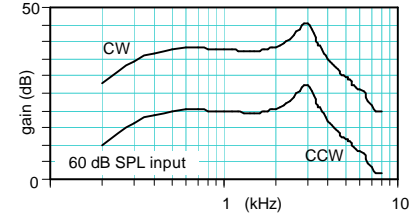

Trimmer VC

use 250 kohm, C2 trimmer

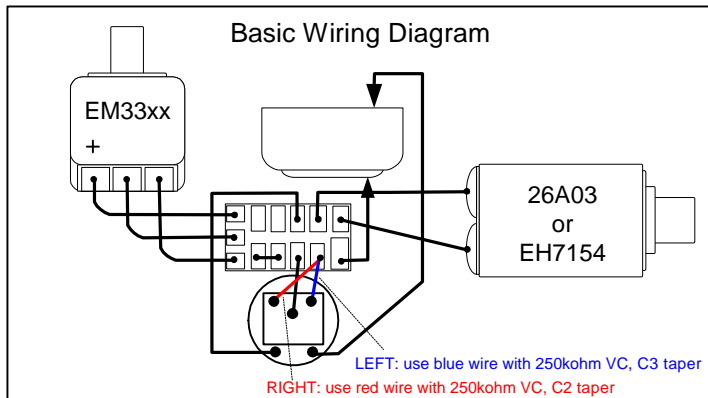
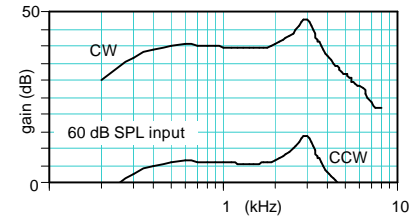

Mic options

slope	R_{mpo}
flat	EM3346
medium	EM3347
high	EM3359

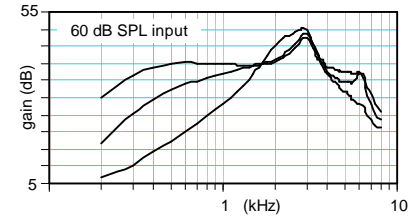

Low Tone Trimmer

remove jumper wire, add .0015uF capacitor and 500 kohm, C22 trimmer

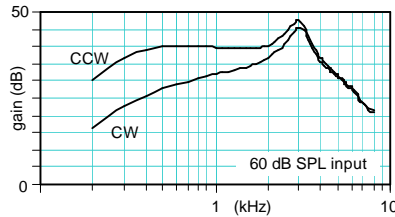

High Tone Trimmer

use .033 uF cap use 75 kohm, C23 trimmer

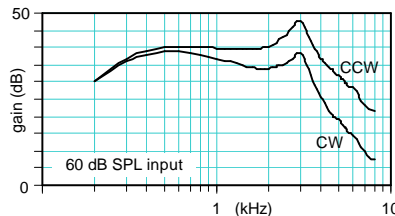

Note: These data are offered to facilitate applications testing for this product. The accuracy of this data is not guaranteed. RTI recommends that the customer perform additional testing prior to production use. Contact RTI if you require additional assistance preparing this product for your application.

Standard Hybrid Package - part number 91104-000

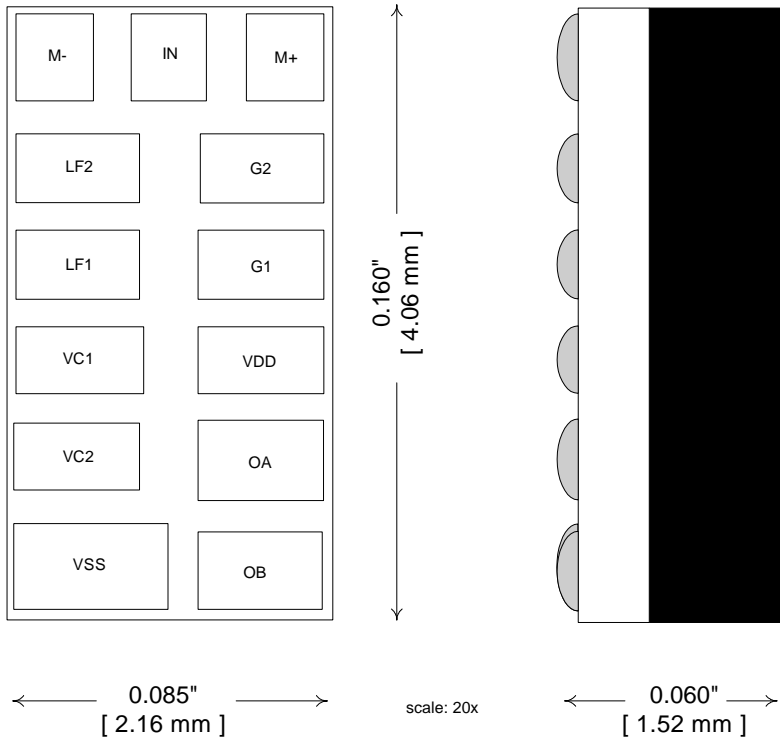

Actual Size

Electrical Performance Data

Absolute Maximum Ratings

Parameter	MIN.	MAX.	Units
Supply Voltage, Vcc		4	V dc
Operating Temperature	10	40	°C
Storage Temperature	-20	70	°C

Electrical Characteristics

Conditions: T = 25°C, Vcc = 1.25V, f = 1kHz, except where noted

Parameter	Conditions	MIN.	TYP	MAX.	Units
Overall					
Supply Voltage, Vcc		1.05	1.25		V dc
Quiescent Current	no output load, no input, no vreg load		220	300	μA
Bandwidth, lower limit	half power limit		100		Hz
Bandwidth, upper limit	half power limit		16,000		Hz
Overall gain	0.71 m V p-p input, 10kohm load, 500kohm VC	63	65	67	dB
Input-referred noise	total rms voltage, 100-10kHz, max gain		1.85		μV
Total harmonic distortion	F = 1 kHz, Vin = 1.6mVpp, 10kΩ load, 500kohm VC		1.2	2	%
Gain variation vs. Vcc	1.05 ≤ Vcc ≤ 1.4 volts	-2		2	dB
Middle Stage					
Gain	VC=500kohm		20		dB
VC range	Delta gain with VC at 0 ohms vs 500k ohms	36	40		dB
Regulator					
Vreg voltage	35μA load	910	930	965	mV
Vreg voltage change	100μA load relative to 35μA load			15	mV
PSRR	1 kHz	60	65		dB
Output noise of Vreg			25		uV
Preamplifier					
Gain	PA_OUT pad open		23		
Input resistance		24k	40k	56k	ohm
Output Stage					
Gain	10k ohm load, DPAO/DPAI open		22	--	dB
Output drive transistors "ON" resistance	Total resistance through both FETs of the conducting part of the H-bridge			30	ohms
Output noise, total rms	D stage input grounded thru cap		75		uV
Trimmed oscillator frequency	no input, 1.1 ≤ Vcc ≤ 1.4 volts	110	125	140	kHz.
Duty cycle	No input, 10kΩ resistive load	49	50	51	%