

# Clari-D™ 285

Product Data Sheet

Features	Benefits
featuring: <b>Clari-D™</b> <i>The Next Generation of Clear Sound Technology</i>	Clearer-sounding, efficient output power for most applications. Eliminates cost of integrated receiver.
Compression Limiting for MPO control	Clean sounding for high output levels, adjustable threshold allows trimmer adjusted MPO
Low Noise Preamp - 1.85uV rms, input referred, typical	Very quiet
Built-in Regulator - no external capacitor required	Good end of life performance, good power supply rejection
Ultra-Small Size: Hybrid is 0.085 x 0.160" [2.16 x 4.06 mm] IC is 0.072 x 0.072" [1.83 x 1.83 mm]	Perfect for tiny CIC aids! Simple solution for all custom applications and low-cost BTE's

## Block Diagram of L285 IC

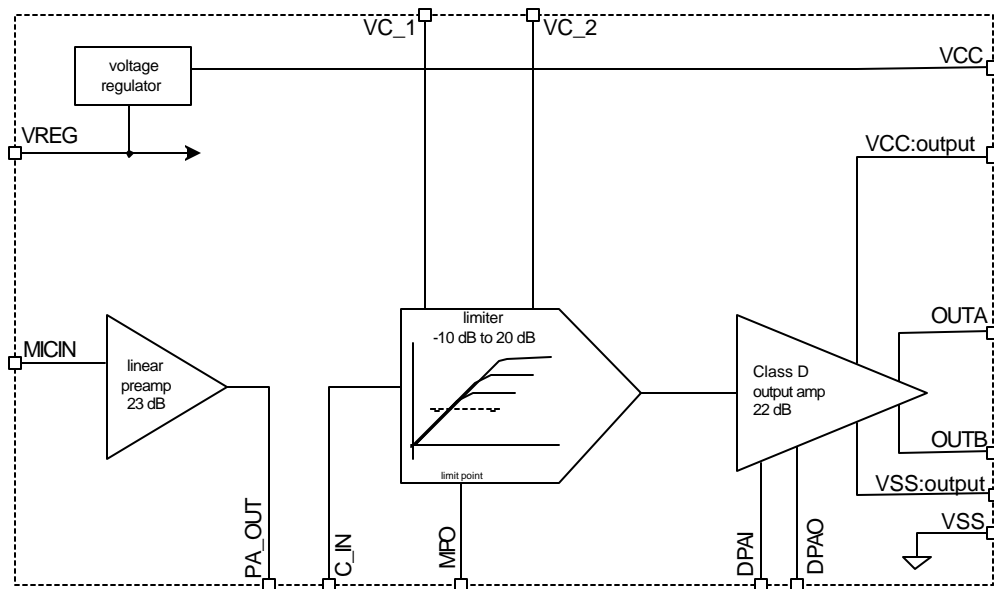

### Resistance Technology, Inc.

1260 Red Fox Road  
 Arden Hills, MN 55112  
 TEL: (651) 636-9770  
 FAX: (651) 636-8944

Visit our Web site at: [www.rti-corp.com](http://www.rti-corp.com)

### Resistance Technology GmbH

Kesselschmiedstrasse 10  
 D-85354 Freising, Germany  
 TEL: 049-8161-4804-0  
 FAX: 049-8161-4804-18

# Typical CIC Application

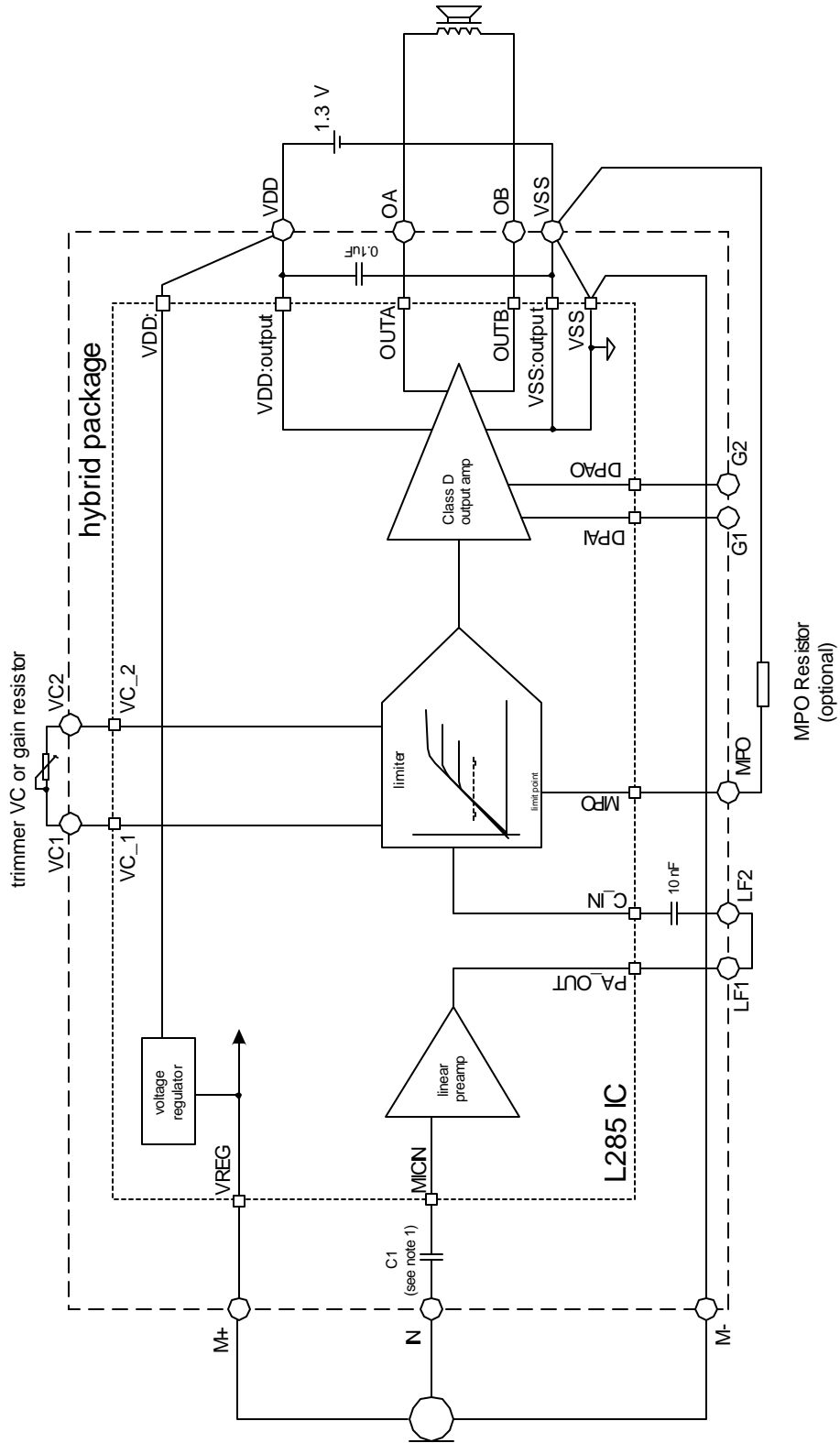

note 1) this value varies by hybrid part number. For pn 91073-00, C1 is 33nF. For pn 91073-001, C1 is 3.3nF.

# Typical Full Feature Application

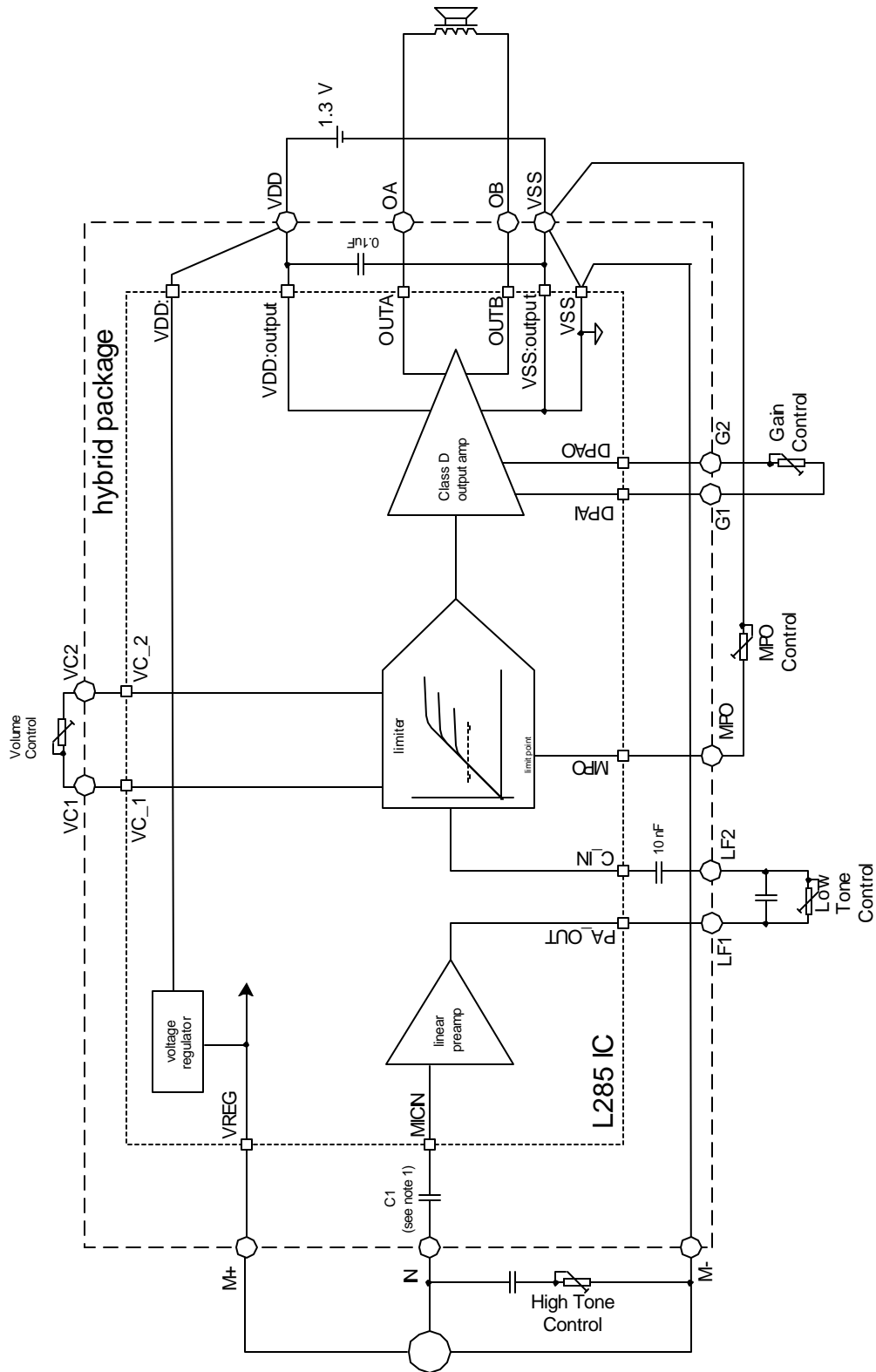

note 1) this value varies by hybrid part number. For part number 91073-000, C1 is 33nF. For part number 91073-001, C1 is 3.3nF.

## Standard Hybrid Package - part number 91073-xxx

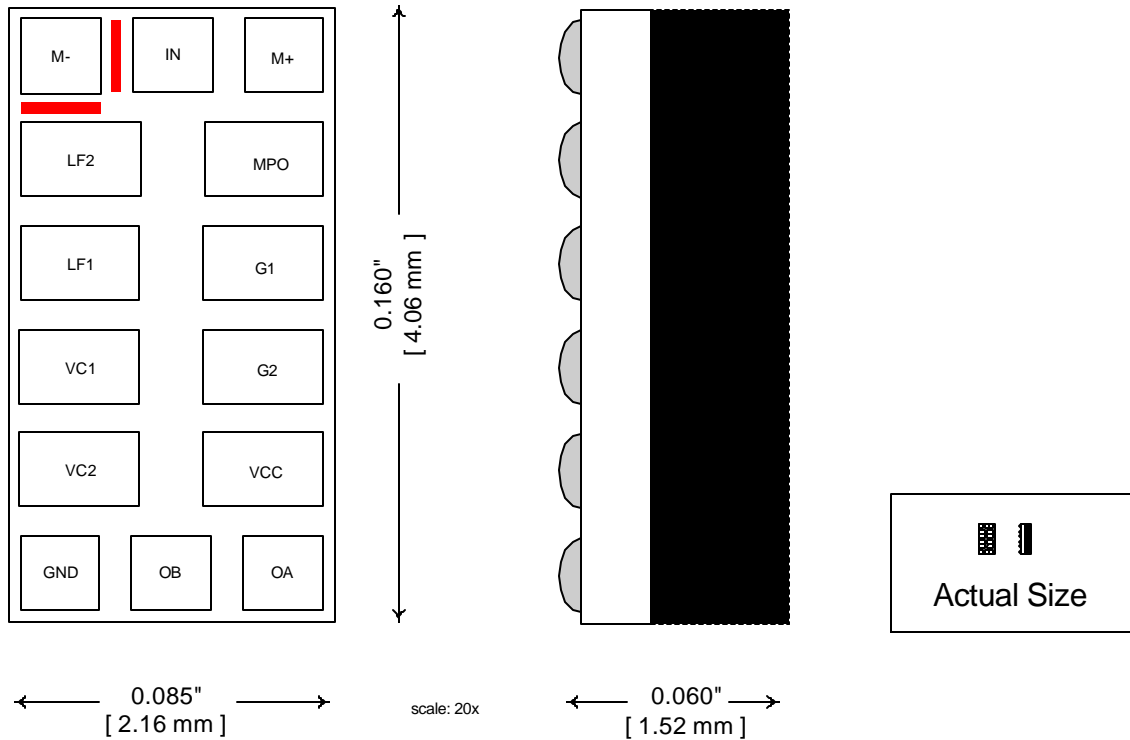

## Dual In-line Package

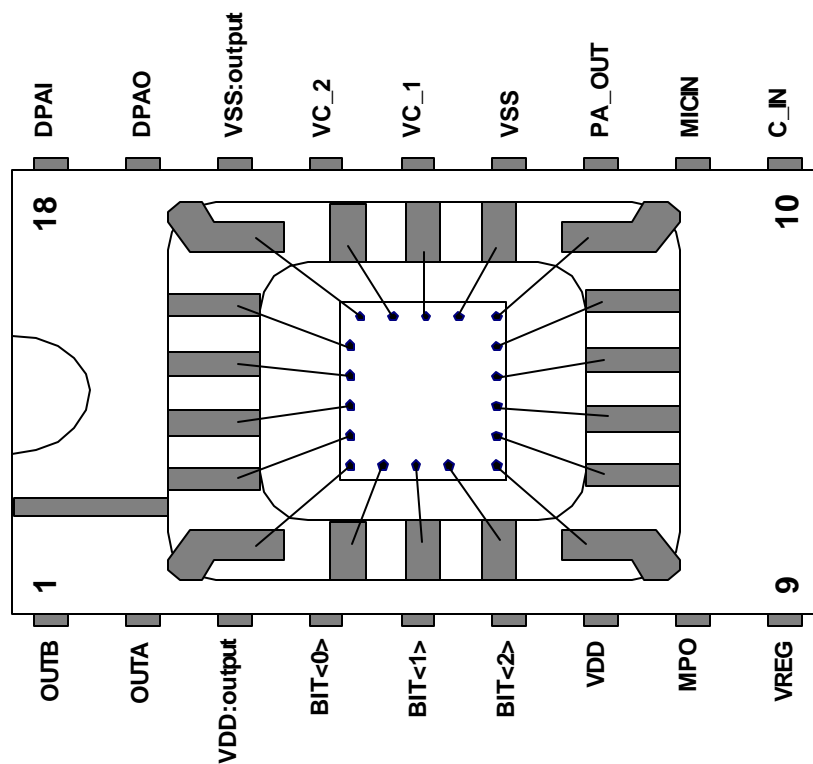

# Electrical Performance Data

## Absolute Maximum Ratings

Parameter	MIN.	MAX.	Units
Supply Voltage, Vcc		4	V dc
Operating Temperature	10	40	°C
Storage Temperature	-20	70	°C

## Electrical Characteristics

Conditions: T = 25°C, Vcc = 1.25V, f = 1kHz, except where noted

Parameter	Conditions	MIN.	TYP	MAX.	Units
<b>Overall</b>					
Supply Voltage, Vcc		1.05	1.25		V dc
Quiescent Current	no output load, no input, no vreg load		220	300	μA
Bandwidth, lower limit	half power limit		100		Hz
Bandwidth, upper limit	half power limit		16,000		Hz
Overall gain	0.71 m V p-p input, 10kohm load, 500kohm VC	63	65	67	dB
Input-referred noise	total rms voltage, 100-10kHz, max gain		1.85		μV
Total harmonic distortion	F = 1 kHz, Vin = 1.6mVpp, 10kΩ load, 500kohm VC, Rmpo=180kΩ		1.2	2	%
Gain variation vs. Vcc	1.05 ≤ Vcc ≤ 1.4 volts	-2		2	dB
<b>Limiters / Compressor</b>					
Threshold adjust range	F = 1 kHz, Vin = 1.6mVpp, 10kΩ load, 500kohm VC, Vary Rmpo from 1MΩ to 68kΩ, measure change in output voltage		27		dB
Compression Ratio		10:1			dB
Attack time	Measured in typical acoustic application according to ANSI S3.22-1996		1	3	Msec
Release time	Measured in typical acoustic application according to ANSI S3.22-1996		75		msec
Gain	Below limiting threshold, VC=500kohm		20		dB
VC range	Delta gain with VC at 0 ohms vs 500k ohms	36	40		dB
<b>Regulator</b>					
Vreg voltage	35μA load	910	930	965	mV
Vreg voltage change	100μA load relative to 35μA load			15	mV
PSRR	1 kHz	60	65		dB
Output noise of Vreg			25		μV
<b>Preamplifier</b>					
Gain	PA_OUT pad open		23		
Input resistance		24k	40k	56k	ohm
<b>Output Stage</b>					
Gain	10k ohm load, DPAO/DPAI open		22	--	dB
Output drive transistors "ON" resistance	Total resistance through both FETs of the conducting part of the H-bridge			30	ohms
Output noise, total rms	D stage input grounded thru cap		75		μV
Trimmed oscillator frequency	no input, 1.1 ≤ Vcc ≤ 1.4 volts	110	125	140	kHz.
Duty cycle	No input, 10kΩ resistive load	49	50	51	%

# Mechanical Plot of Solder Bumped IC (pn 80635-001)

Pad positions  
(center of pad relative to center of IC, in thousandths of an inch)

PAD Name	X	Y
VDD:output	-29.5	26.4
BIT<0>	-29.5	14.6
BIT<1>	-29.5	2.8
BIT<2>	-29.5	-9.0
VDD	-29.5	-26.4
MPO	-17.8	-26.4
VREG	-6.0	-26.4
C_IN	5.8	-26.4
MICIN	17.7	-26.4
PA_OUT	29.5	-26.4
VSS	29.5	-12.8
VC_1	29.5	-0.9
VC_2	29.5	10.9
VSS:output	29.5	22.7
DPAO	17.8	26.4
DPAI	6.0	26.4
OUTB	-5.8	26.4
OUTA	-17.6	26.4

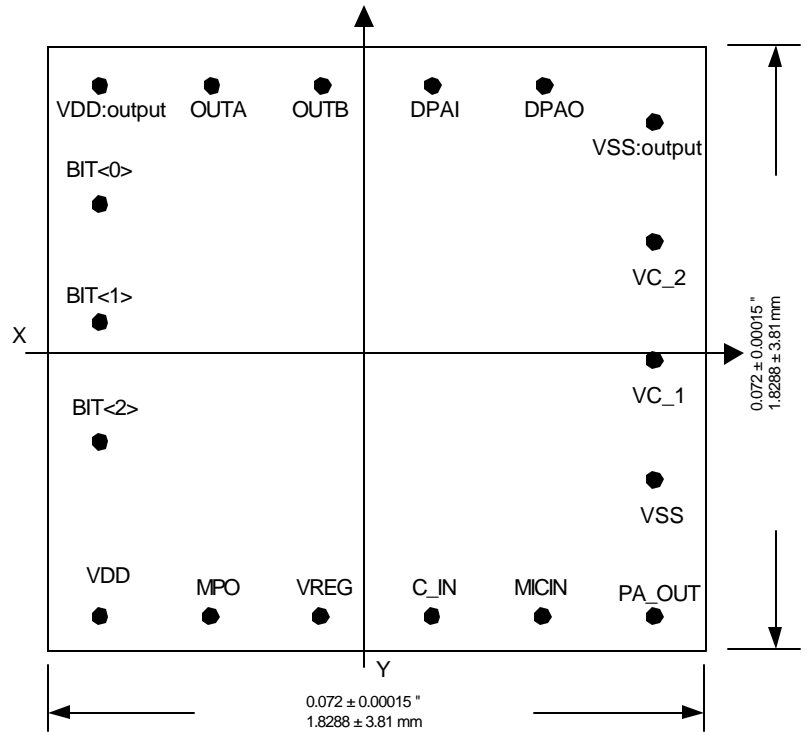

Die Thickness: 0.019 ± 0.001" [0.4826 ± .025 mm]

## Solder Bump Cross-Section

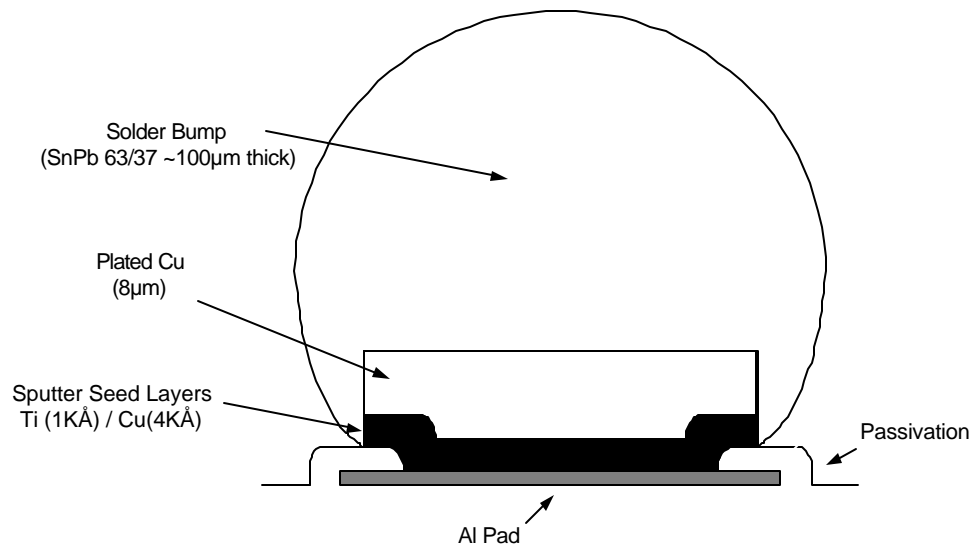

Bump Height = 100 µm nominal  
Bump Shear Strength = 2.0 grams/mil<sup>2</sup> of bump area.