

# 2704 AGC Class B amplifier

Product Data Sheet

Features	Benefits
<b>2704 AGC preamplifier with Class B output stage</b>	Low cost hybrid.
Preamplifier capable of AGC1, AGC0 or linear operation	Clean sound for high output levels, adjustable threshold
44dB Gain preamplifier	Works well in all custom applications and low-cost BTE's
Built-in Regulator - no external capacitor required	Good power supply rejection
Class B output stage	High gain and power levels

**Block Diagram of 2704 IC**

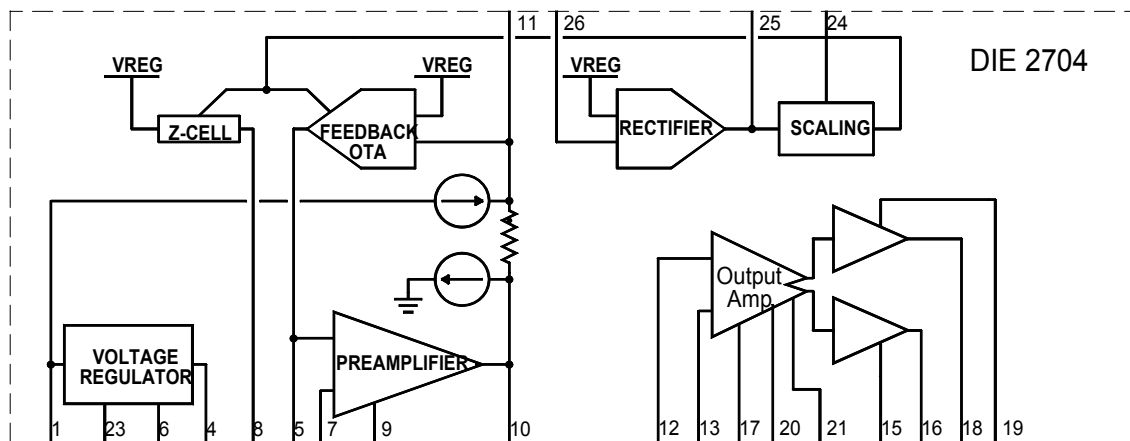

**Resistance Technology, Inc.**

1260 Red Fox Road  
 Arden Hills, MN 55112  
 TEL: (651) 636-9770  
 FAX: (651) 636-8944

Visit our Web site at: [www.rti-corp.com](http://www.rti-corp.com)

**Resistance Technology GmbH**

Kesselschmiedstrasse 10  
 D-85354 Freising, Germany  
 TEL: 049-8161-4804-0  
 FAX: 049-8161-4804-18

# Typical Application

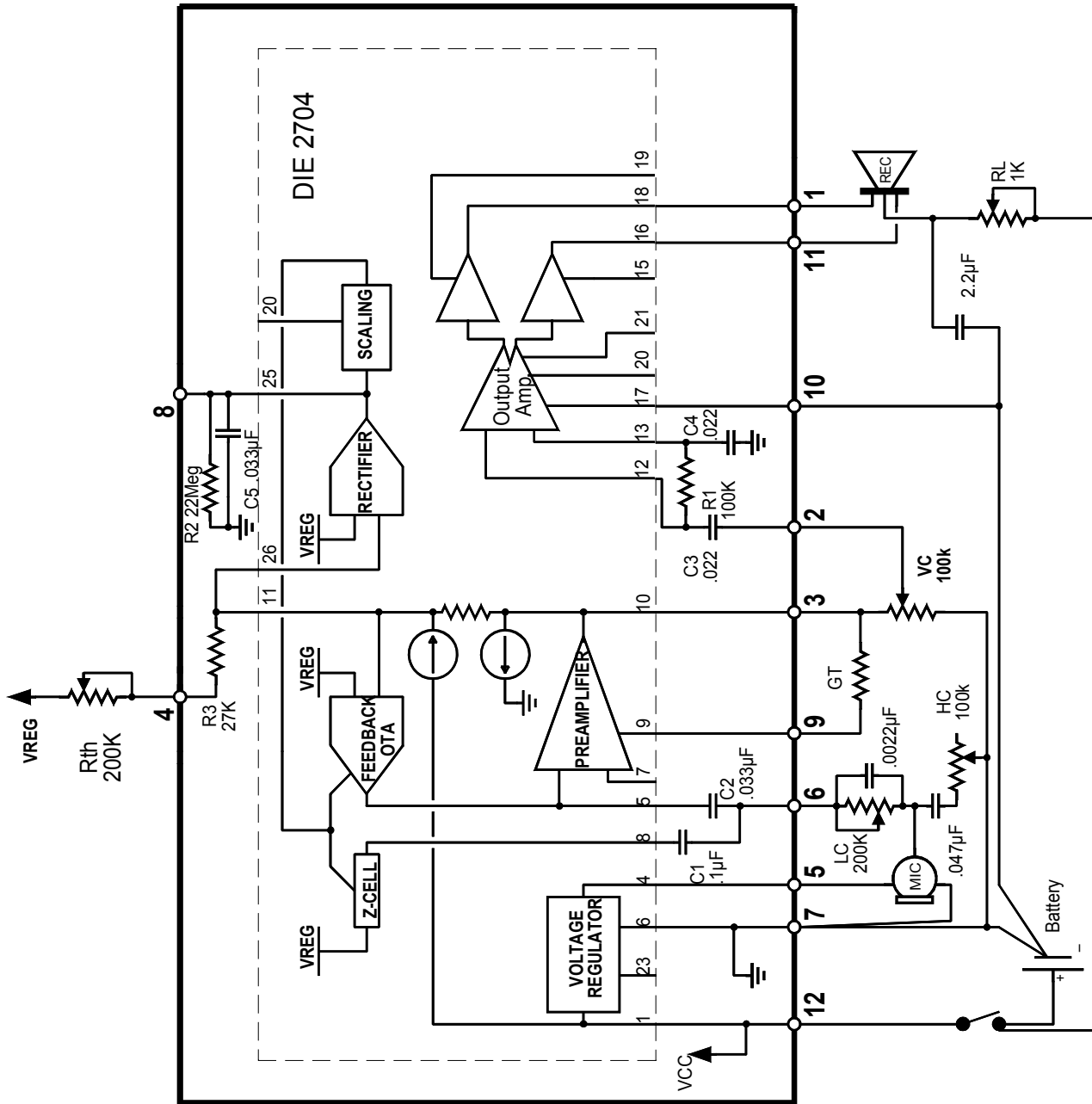

# Standard Hybrid Package - part number 91311-000

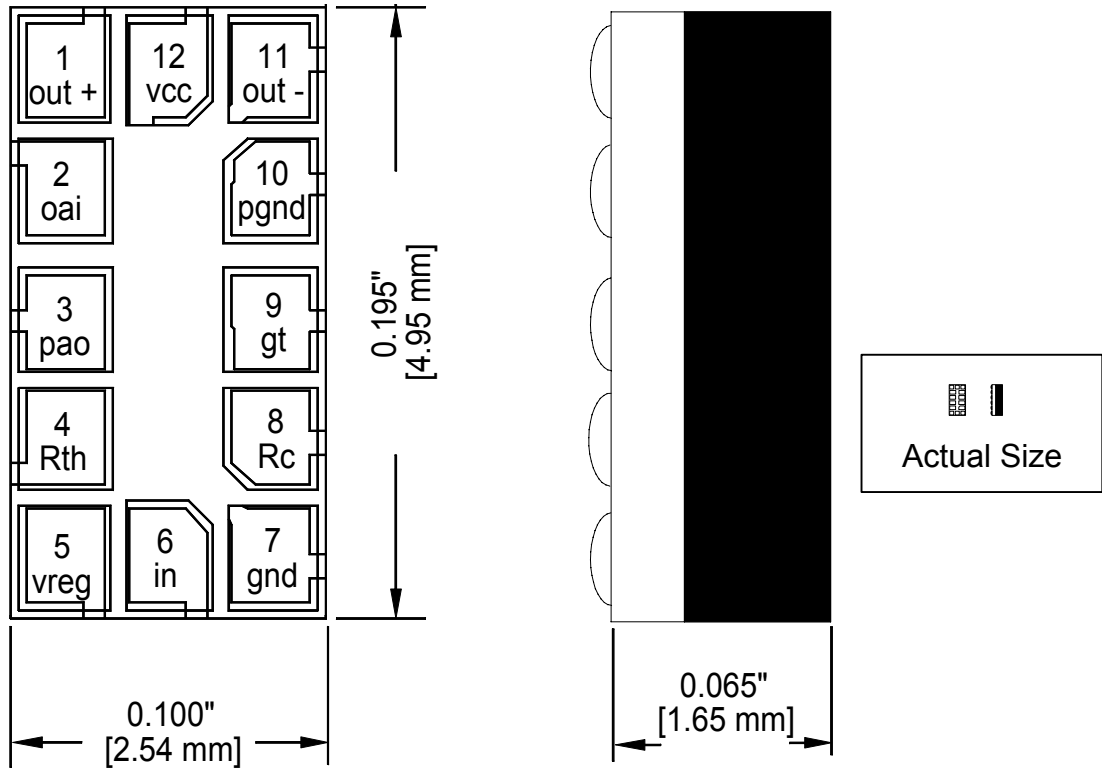

## 2704 AGC PRODUCT SPECIFICATIONS

2704 DIE	MIN.	TYP	MAX.	UNITS
Dropout Voltage	--	--	1.05	V dc
Quiescent Current (see Figure 1)	--	250	350	mA
<b>2704 VOLTAGE REGULATOR</b>				
Output Voltage	.86	--	.93	V dc
Power Supply Rejection Ratio @ 1kHz	60	70	--	dB
Noise (BW = 10kHz)	--	25	32	mV
Output Impedance @ 1kHz	.25	.50	1.50	$\Omega$
Output Current	50	--	--	$\mu$ A
Temperature Coefficient of Output Voltage	-.17	-.12	-.07	%/ $^{\circ}$ C
<b>2704 PREAMPLIFIER</b>				
Equivalent Input Noise <sup>i</sup>	--	2.7	3.8	$\mu$ V rms
Input Impedance at Preamp Input Pin @ 1kHz	80	100	120	k $\Omega$
Output Impedance @ 1kHz	35	75	250	$\Omega$
Voltage Gain Preamp In to Preamp Out @ 1kHz	42	43	44	dB
Output Bias Voltage <sup>ii</sup>	350	--	750	mV
Output Voltage Swing (open loop)	600	--	--	mV p-p
Output Bandwidth <sup>iii</sup>	3.0	4.8	--	kHz
Output Current Capability	300	--	--	$\mu$ A
Distortion (Input 1mV @ 1kHz)	--	--	2	%
<b>2704 RECTIFIER (see Figure 4)</b>				
Output Current <sup>iv</sup>	2.2	3.1	5.3	$\mu$ A
Threshold Voltage	10	14	19	mVpk
Compression Ratio <sup>v</sup>	3:1		10:1	
<b>2704 OUTPUT AMPLIFIER (see Figure 5)</b>				
Quiescent Current <sup>vi</sup>	--	90	320	$\mu$ A
Input Impedance	70	92	114	k $\Omega$
Voltage Gain <sup>vii</sup>	27	30	32	dB
Output Current Capability	40	--	--	mA

USA PATENTS ISSUED: 4,743,833 4,764,733 4,973,917

RTI reserves the right to make changes at any time to improve reliability, function or design, in order to provide the best possible product.

<sup>i</sup> The preamplifier input is capacitor coupled to a 3.9k $\Omega$  load (to simulate the output impedance of a typical microphone), and the voltage spectral noise density, in dB, is measured at the output of the preamplifier. The dc gain of the preamplifier, in dB, is subtracted from the measured noise giving a referred input noise. The total referred input noise is calculated by piecewise integration (see Fig. 2 and 3). The noise can also be approximated with a noise floor of  $\approx$ 150dB, or  $\approx$ 31.6nV and if a frequency range of 100 to 10kHz is assumed then  $EIN=31.6nV \cdot \sqrt{(9.9kHz)} \approx 3\mu V$ .

<sup>ii</sup> The range of the bias voltage improves when the AGC loop is closed. In this case the output bias voltage minimum is 500mV and the maximum is 700mV.

<sup>iii</sup> The preamplifier is a dc amplifier, which has been internally compensated to prevent oscillation. With this compensation the gain is guaranteed to be flat with a -3dB knee of  $\geq$ 3kHz.

<sup>iv</sup> The maximum output with  $\pm$ 100mV of offset applied to the differential input of the rectifier (one side connected to Vreg).

<sup>v</sup> The compression ratio is calculated by analyzing the slope of the curve (above the threshold knee) as seen on the ANSI I/O curve, where the ratio is the input dB change vs. the output dB change. Adjusted with Compression Ratio control (open is 10:1)

<sup>vi</sup> The quiescent (no-signal) current will vary with the receiver impedance and the settings of the output drive control and the current feedback control.

<sup>vii</sup> The voltage gain specification shown assumes that the boost function is not used to increase the gain, and that the current feedback or output drive control are not used to reduce the gain.

**2704 class B  
PN 91311-000  
linear mode**

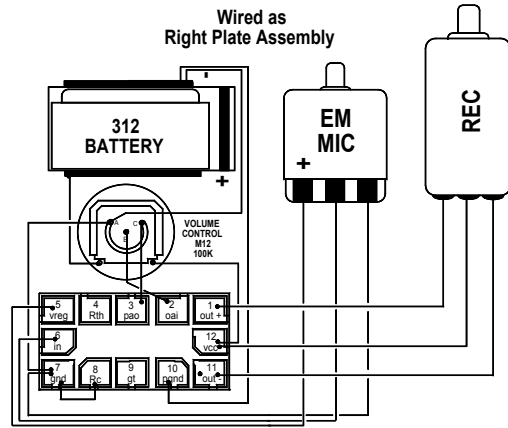
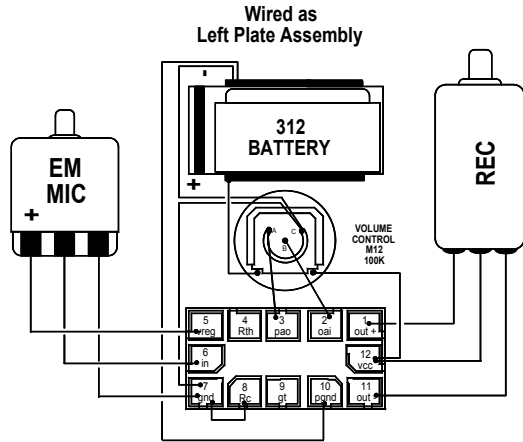

**2704 class B  
PN 91311-000  
AGCI mode**

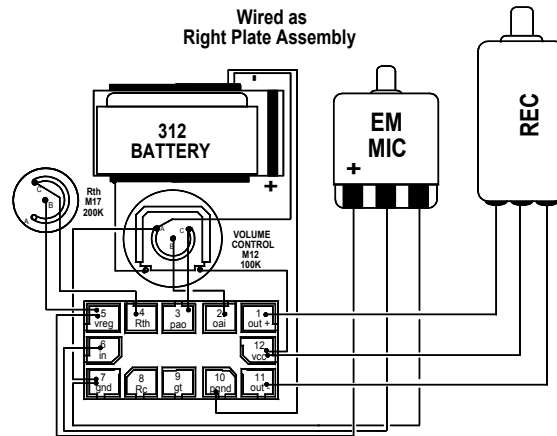
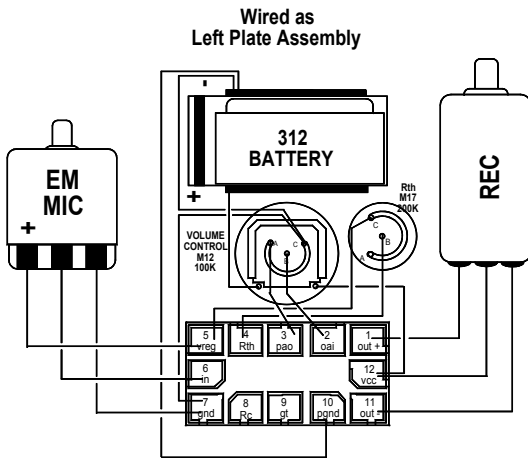

**2704 class B  
PN 91311-000  
AGCO mode**

